

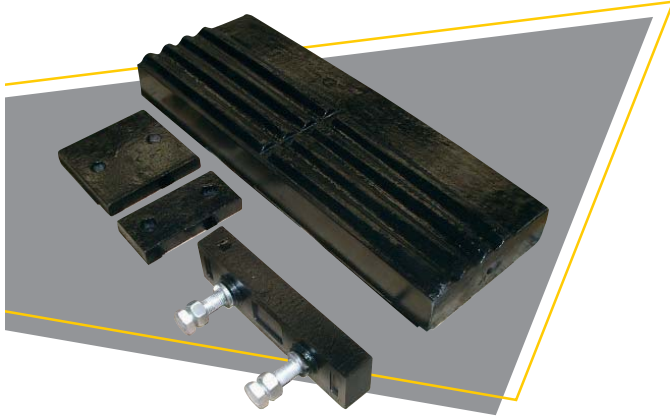

Spare Parts & Product Support Services



GENUINE STRIKER SPARE PARTS

Don't compromise reliability and performance of your STRIKER Crusher. We offer a complete range of Genuine STRIKER wear parts & spare parts.

HYDRAULIC COMPONENTS

A comprehensive range of Sauer Danfoss hydraulic pumps, motors, valves, etc. These are Original Equipment supply for your STRIKER.

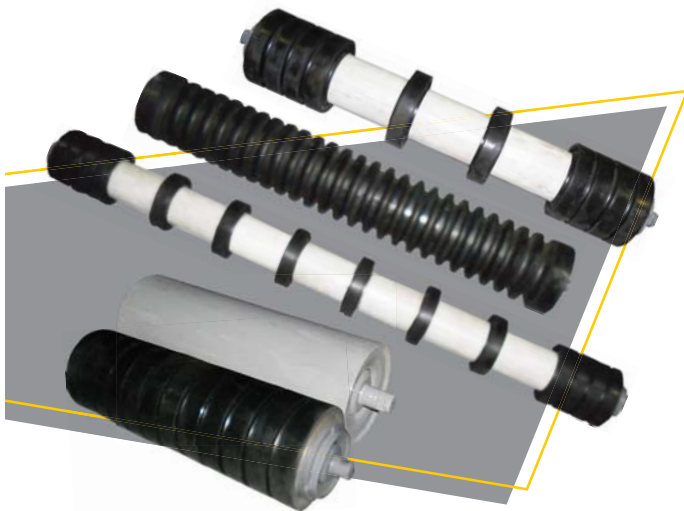
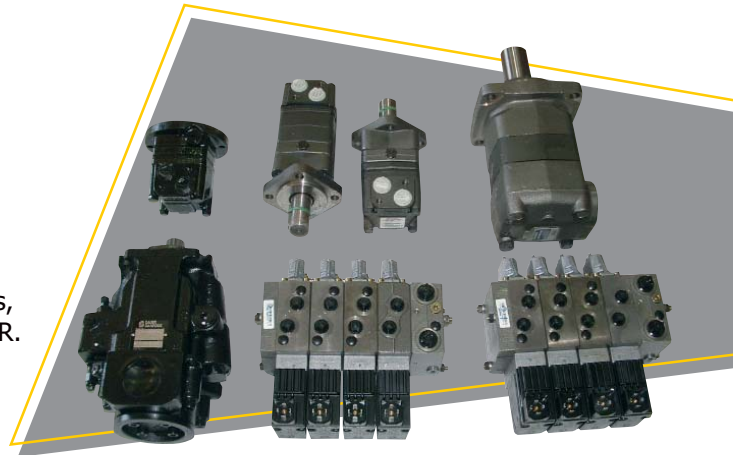

CONVEYOR ROLLERS & IDLERS

A full range of conveyor rollers to suit a wide variety of track crushers and screens including:

STRIKER, PARKER, FINLAY, POWERSCREEN, EXTEC PEGSON

CONVEYOR DRIVE & TAIL PULLEYS

STRIKER can provide a wide range of drive and driven pulleys to suit your needs. These can be supplied as bare pulley or complete with bearings attached for quick & easy installation.

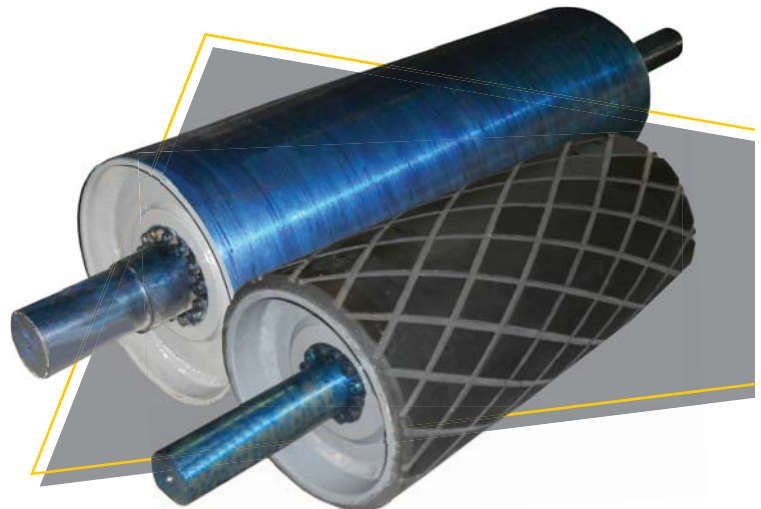

MISCELLANEOUS PARTS

STRIKER offer a full range of spare parts to suit most applications including:

'V' BELTS, CONVEYOR BELTS, BEARINGS, ROSTA TENSIONERS, DRIVE COUPLINGS, HYDRAULIC CYLINDERS, SKIRT RUBBER, SPRINGS, KPTO/HFO TRANSFLUID TRANSMISSION

GREASE SYSTEMS

Complete centralized grease systems and parts. Fully automatic systems or simple hand operated units available to suit your needs. We can design 'after market' lube systems if required.

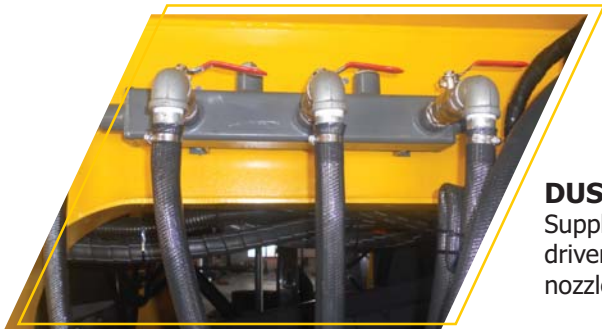

DUST SUPPRESSION

Supplying a unique dust suppression system for any application. Hydraulic driven water pump, hosing, solid spray bars and a huge range of sprinkler nozzles are available.

MAGNETS

STRIKER offer a full range of magnets for all applications. These permanent and Electro magnets can be manufactured to suit your needs and an installation service is available.



VIBRATING FEEDER DRIVES

STRIKER vibrating feeder drives are available new or as a service exchange unit.

ROCK BOOM SYSTEMS

STRIKER can tailor make a rock boom system to suit your needs, from new installations, to fitting a boom system to your existing mobile or fixed plant.

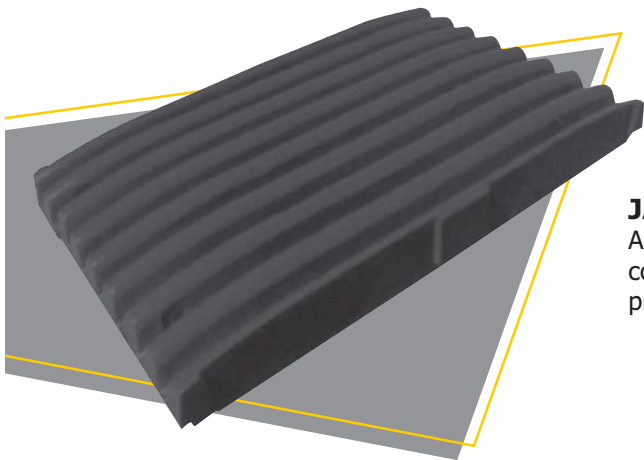

JAW & CONE CRUSHER PARTS

A full range of wear parts, bushes and spare parts are available to suit most common jaw & cone crushers, All parts are available at very competitive prices.

PERTH OFFICE: 9 Egmont Road Henderson WA 6166, Australia

Ph: +61 8 9437 3533 **Fax:** +61 8 9437 3544 **E-mail:** spareswa@strikercrushing.com

BRISBANE OFFICE: 26 Leonard Crescent Brendale QLD 4500, Australia

Ph: +61 7 3881 1227 **Fax:** +61 7 3881 1996 **E-mail:** sparesqld@strikercrushing.com

www.strikercrushing.com



STRIKER

CRUSHING & SCREENING

ROCKBOOM SYSTEMS

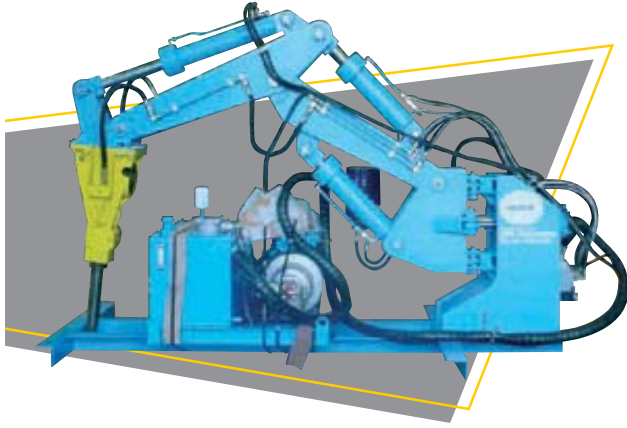

STRIKER offer a full range of rock boom systems to suit all applications, from fixed plant to mobile plant.

STRIKER can tailor make a rock boom system to suit your needs, from new installations, to fitting a boom system to your existing mobile or fixed plant.



PERTH OFFICE: 9 Egmont Road Henderson WA 6166, Australia
Ph: +61 8 9437 3533 **Fax:** +61 8 9437 3544 **E-mail:** spareswa@strikercrushing.com

BRISBANE OFFICE: 26 Leonard Crescent Brendale QLD 4500, Australia
Ph: +61 7 3881 1227 **Fax:** +61 7 3881 1996 **E-mail:** sparesqld@strikercrushing.com

www.strikercrushing.com